

C2

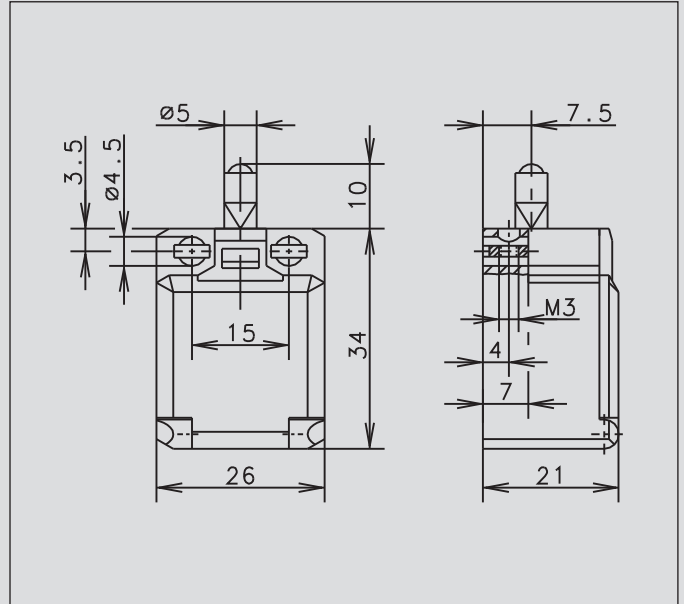

Recommended use

Ideal for safety applications and position monitoring in confined spaces.

Product advantages

- Miniature switch for safety applications
- Two-channel safety monitoring possible
- With captive snap-on cover
- Small hysteresis in snap action system

Design layout

- Slow-action and snap-action contacts
- Versions: 1 NC / 1NO, 2 NC, 2 NO
- All NC contacts with \ominus in the circuit diagram are positively opening contacts
- Type: Zb (galvanically isolated changeover contact)

Mounting

- Also suitable for front mounting (depending on type)

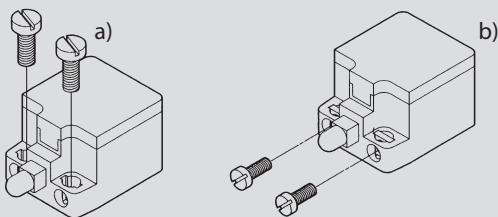

- a) 2 round holes for M4 screws
- b) 2 Integrated nuts for front mounting for M3 screws (depending on type)

Installation advantages

- Snap-on cover can be released with screwdriver
- Cover opening range 180° (cover can also be detached from hinge)
- Cover protects switching element during installation
- Screw connections with self-lifting clamping plates
- Cover transparent for adjustment and visual inspection
- Easy-action cover lock (close and press)

Technical data

Electrical data		
Rated insulation voltage	U_i max.	240 V AC
Conventional thermal current	I_{the}	10 A
Rated operating voltage	U_e max.	240 V
Utilisation category	U_e/I_e	AC-15, U_e/I_e 240 V/3 A
Short-circuit protection		Fuse 6 A gL/gG
Protection class		II, Insulated
Mechanical data		
Enclosure material		Thermoplastic, glass fibre-reinforced (UL 94-V0)
Ambient temperature		-30 °C to +80 °C
Mechanical service life		3×10^6 switching cycles
B10d		6 Mio.
Switching frequency		≤ 100 /min
Type of connection		Screw connections
Conductor cross sections		Single-wire 0.5 – 1.5 mm ² or Stranded wire with ferrule 0.5 – 1.5 mm ²
Cable entry		Rectangle 8.5 x 3.5 mm
Protection class		IP20 conforming to EN 60529; DIN VDE 0470 T1
Standards		
VDE 0660 T100, DIN EN 60947-1, IEC 60947-1		
VDE 0660 T200, DIN EN 60947-5-1, IEC 60947-5-1		

W

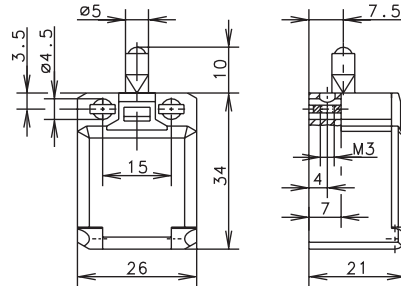

ST

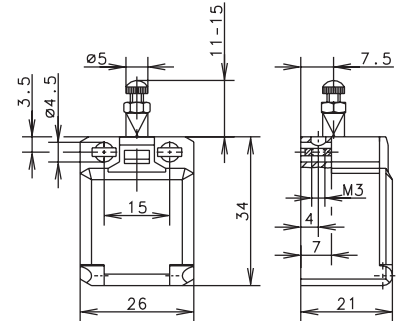

Switching operation

1 NC / 1 NO contact

Slow-action

Snap-action

6008101001
C2-U1Z

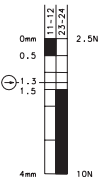

6008351002
C2-SU1Z

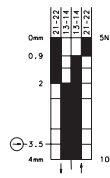

Slow-action

Snap-action

6008104025
C2-U1Z ST

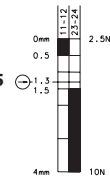

6008354026
C2-SU1Z ST

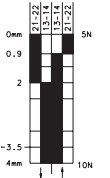

2 NC contacts

6008801003
C2-A2Z



6008851004
C2-SA2Z

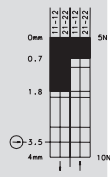

6008804027
C2-A2Z ST

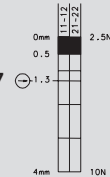

2 NO contacts

6008801005
C2-E2

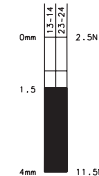

6008851006
C2-SE2

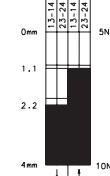

6008804029
C2-E2 ST

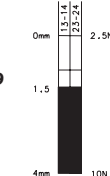

1 NC / 1 NO contact
Overlapping

Approvals



Replacement actuator: -

Replacement actuator: -

Special features / variants
(on request)

Special features / variants

- Actuator length adjustable with adjusting screw

K

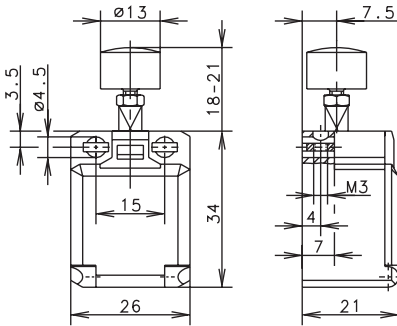

R

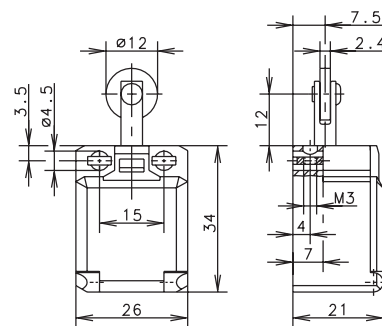

O.M.

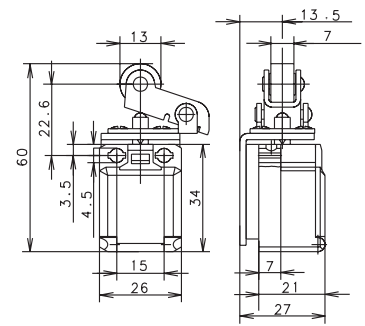

Slow-action

Snap-action

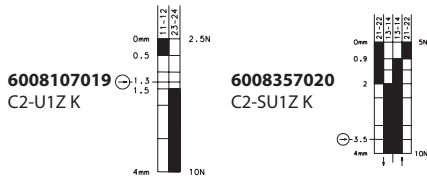

Slow-action

Snap-action

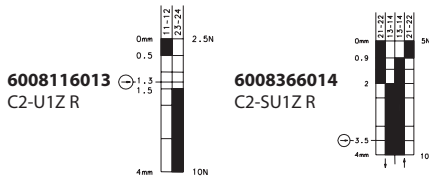

Slow-action

Snap-action

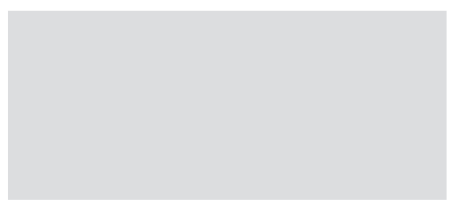
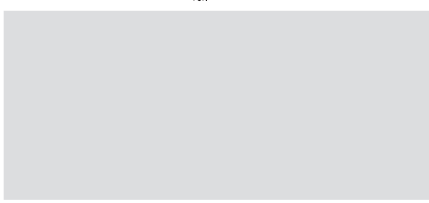
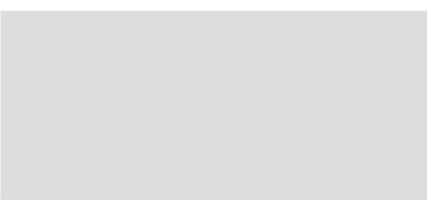
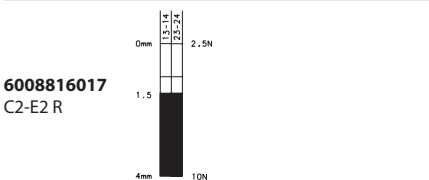
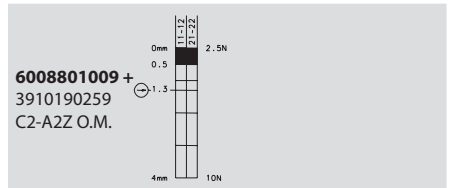
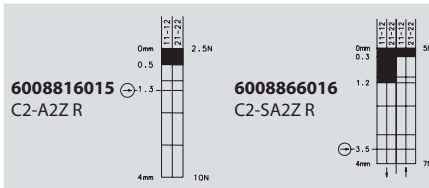
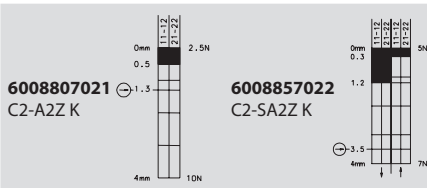
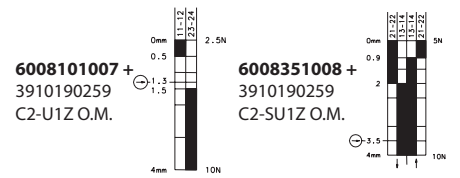

Replacement actuator: –

Replacement actuator: –

Replacement actuator: 3910190259

Special features / variants

- Button actuator, for manual operation

Special features / variants

(on request)

- Also available with roller turned by 90°

Special features / variants

(on request)

BISTABLE O.M.

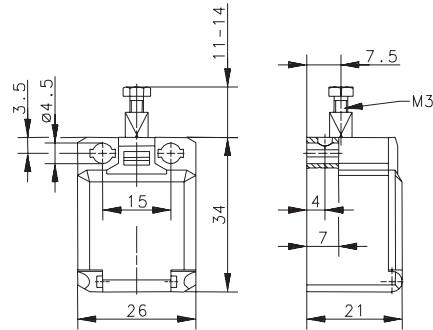

Switching operation

Slow-action

Snap-action

1 NC / 1 NO contact

6108351008
C2-SU1Z
BISTABLE O.M.

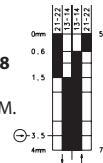

2 NC contacts

2 NO contacts

1 NC / 1 NO contact
Overlapping

Approvals

Replacement actuator: -

Special features / variants

- Bistable characteristics, actuator must be returned to initial position by external actuation (pulling)
- Actuator length adjustable with M3 adjusting screw